

FL ISOLATOR 100-M12 - Network isolator



2902985

<https://www.phoenixcontact.com/sg/products/2902985>

Please be informed that the data shown in this PDF document is generated from our online catalog. Please find the complete data in the user documentation. Our general terms of use for downloads are valid.



Passive network isolator for electrical isolation in Ethernet networks. For the protection of Ethernet devices against potential differences of up to 4 kV. Can be used for transmission speeds of up to 100 Mbps. Ethernet connection via two M12 sockets (D-coded).

Product description

The FL ISOLATOR 100-M12 has been specifically developed for use in the railway industry. Featuring M12 connection technology and optional panel mounting, this network isolator can be used flexibly.

Your advantages

- No power supply required
- Dielectric strength of up to 4 kV
- Continuous insulation voltage of 250 VRMS
- Protection against aggressive environmental influences, particularly harsh industrial environments, thanks to coated PCB
- Approval for railway applications (rolling stock) in accordance with EN 50155 and EN 50121
- Panel mounting
- Extended temperature range of -40 °C ... +75 °C

Commercial data

Item number	2902985
Packing unit	1 pc
Minimum order quantity	1 pc
Sales key	*****
Product key	DNC332
Catalog page	Page 365 (C-6-2019)
GTIN	4046356727815
Weight per piece (including packing)	144.5 g
Weight per piece (excluding packing)	94.91 g
Customs tariff number	85176990
Country of origin	DE

FL ISOLATOR 100-M12 - Network isolator



2902985

<https://www.phoenixcontact.com/sg/products/2902985>

Technical data

Notes

Note on application

Note on application	Only for industrial use
---------------------	-------------------------

Product properties

Product type	Network isolator
MTTF	18372 Years (SN 29500 standard, temperature 25°C, operating cycle 21%)
	13381 Years (SN 29500 standard, temperature 40°C, operating cycle 34.25%)
	3348 Years (SN 29500 standard, temperature 40°C, operating cycle 100%)
MTBF	38062 Years (Telcordia standard, 25°C temperature, 21% operating cycle (5 days a week, 8 hours a day))
	12264 Years (Telcordia standard, 40°C temperature, 34.25% operating cycle (5 days a week, 12 hours a day))

Electrical properties

Electrical isolation	Port X1//port X2
Insulation voltage input/output	250 V _{rms}
Test voltage data interface/data interface	4 kV AC (50 Hz, 1 min.)

Supply

Supply voltage range	passive module, no supply voltage required
----------------------	--

Interfaces

Signal	Ethernet
	PROFINET

Data: Ethernet interface, 10/100Base-T(X) in accordance with IEEE 802.3

Serial transmission speed	10/100 Mbps
Connection method	M12 connector, D-coded (female)
No. of channels	1
Tightening torque	≤ 2 Nm
Transmission length	≤ 100 m (Total length across both ports (dependent on data rate and cable used))
Protocols supported	Transparent protocol for IPv4 and IPv6

Data: Ethernet interface, 10/100Base-T(X) in accordance with IEEE 802.3

Connection method	M12 connector, D-coded (female)
No. of channels	1

Dimensions

FL ISOLATOR 100-M12 - Network isolator



2902985

<https://www.phoenixcontact.com/sg/products/2902985>

Dimensional drawing	
Width	66 mm
Height	91 mm
Depth	34 mm

Material specifications

Color (Housing)	black (RAL 9005)
Material (Housing)	Polycarbonate
Material (Lower part)	PC-ABS

Cable/line

Shielding	no connection to protective earth ground (PE) capacitive isolation between both shield connections
-----------	---

Mechanical tests

Vibration resistance in accordance with EN 60068-2-6/IEC 60068-2-6	Vibration (operation): 5g, 10...150 Hz, 2.5 h, in XYZ direction
Vibration resistance according to IEC 61373, EN 61373	Vibration (operation), IEC: Category 1, Class B
Shock in accordance with EN 60068-2-27/IEC 60068-2-27	Shock (operation): 15g, 11 ms period, half-sine shock pulse Shock (storage/transport): 30g, 18 ms period, half-sine shock pulse

Environmental and real-life conditions

Ambient conditions

Degree of protection	IP54
Ambient temperature (operation)	-40 °C ... 75 °C (85°C for 10 min.; thereafter function can no longer be guaranteed - check device)
Ambient temperature (storage/transport)	-40 °C ... 75 °C
Altitude	≤ 5000 m (For restrictions, see the manufacturer's declaration for altitude operation)
Permissible humidity (operation)	10 % ... 95 %
Permissible humidity (storage/transport)	5 % ... 95 %

Approvals

CE

Certificate	CE-compliant
-------------	--------------

Corrosive gas test

FL ISOLATOR 100-M12 - Network isolator



2902985

<https://www.phoenixcontact.com/sg/products/2902985>

Identification	ISA-S71.04-1985 G3 Harsh Group A
----------------	----------------------------------

EMC data

Electromagnetic compatibility	Conformance with EMC Directive 2014/30/EU
-------------------------------	---

Fast transients (burst)

Standards/regulations	EN 61000-4-4
-----------------------	--------------

Emitted interference

Standards/regulations	EN 61000-6-4
Radio interference voltage in acc. with EN 55011	Class B, area of application: Industry and residential
Emitted radio interference in acc. with EN 55011	Class B, area of application: Industry and residential

Standards and regulations

Standards/regulations	EN 50121 and EN 50155 (for railway applications)
	IEC 60571
	IEC 62368
	Suitable in accordance with SELV EN 50153

Mounting

Mounting type	Panel mounting
---------------	----------------

FL ISOLATOR 100-M12 - Network isolator

2902985

<https://www.phoenixcontact.com/sg/products/2902985>

Drawings

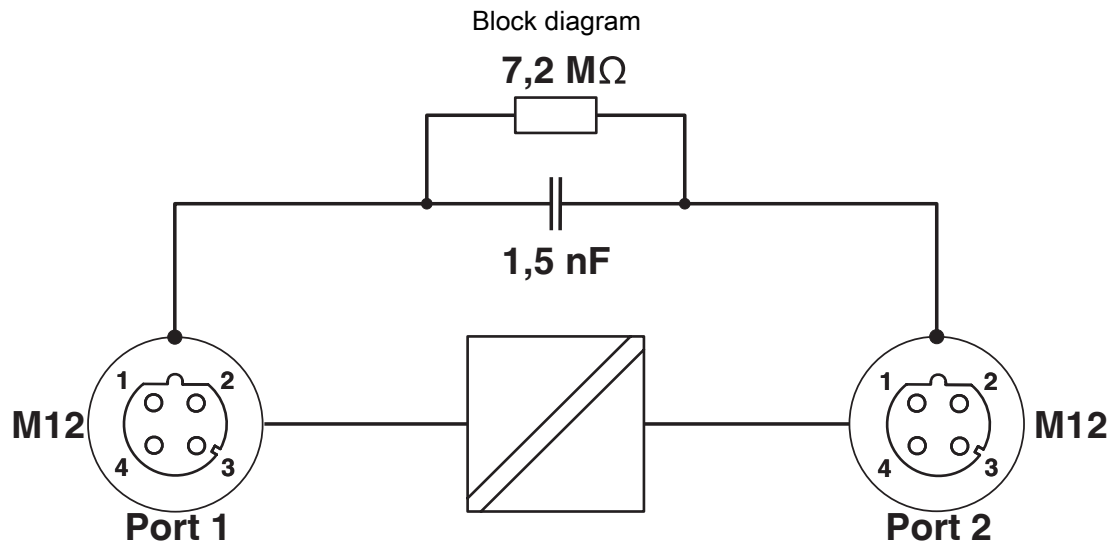

Basic circuit diagram

Dimensional drawing

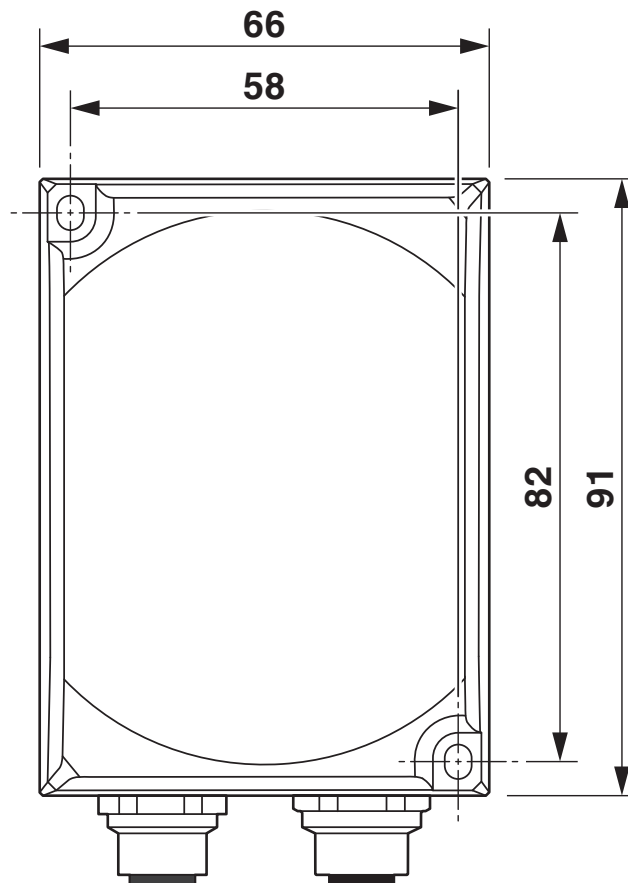

Dimensions and drill hole spacing in mm

FL ISOLATOR 100-M12 - Network isolator



2902985

<https://www.phoenixcontact.com/sg/products/2902985>

Schematic diagram

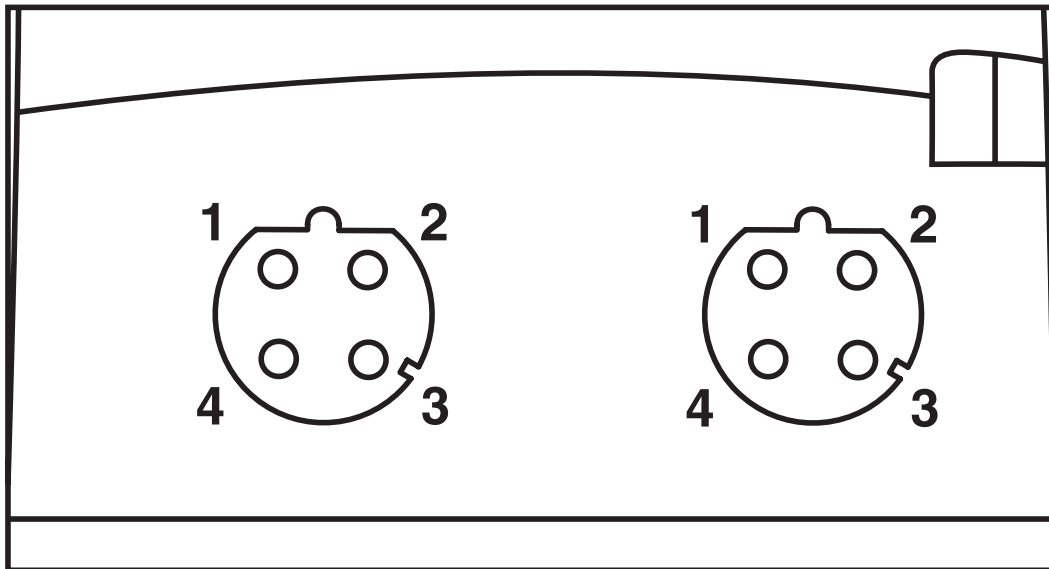

View from below

Schematic diagram

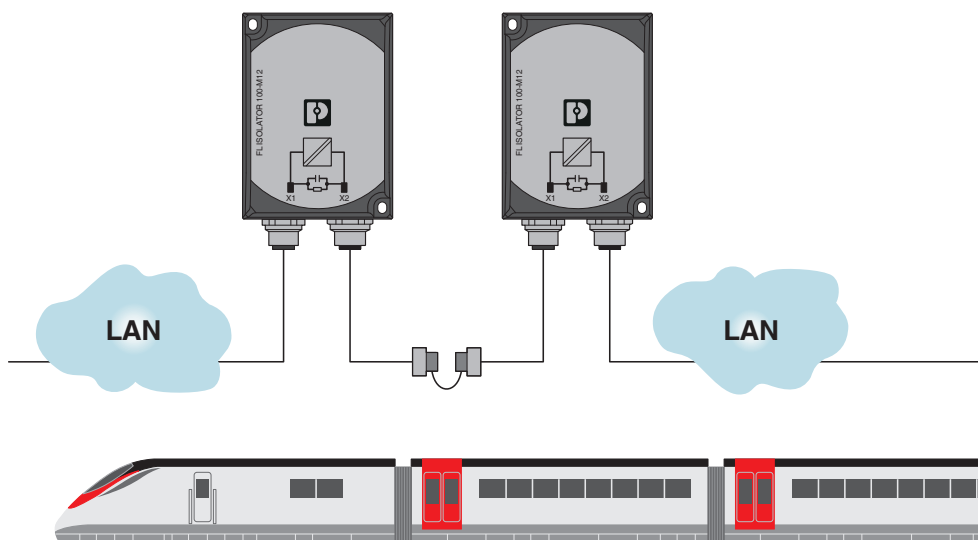

Railway application: isolation of train sections

FL ISOLATOR 100-M12 - Network isolator

2902985

<https://www.phoenixcontact.com/sg/products/2902985>



Application drawing

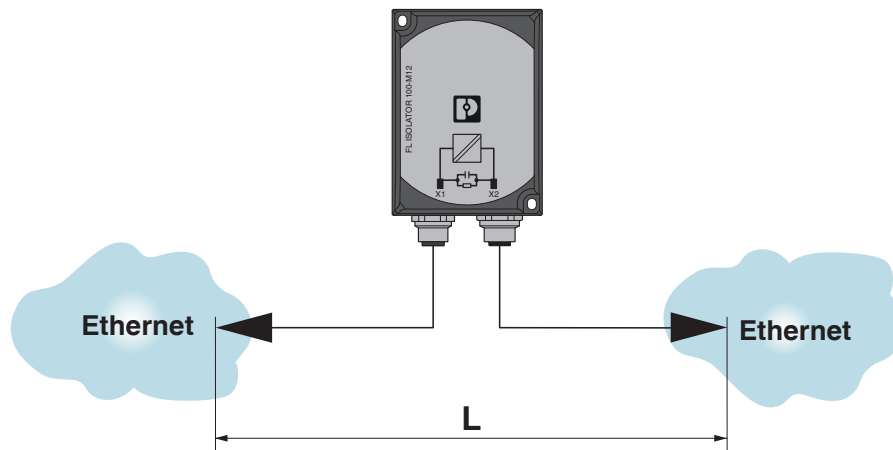

FL ISOLATOR 100-M12 - Network isolator



2902985

<https://www.phoenixcontact.com/sg/products/2902985>

Classifications

ECLASS

ECLASS-11.0	27240692
ECLASS-13.0	27240692
ECLASS-12.0	27240692

ETIM

ETIM 9.0	EC002584
----------	----------

UNSPSC

UNSPSC 21.0	39121400
-------------	----------

Environmental product compliance

EU RoHS

Fulfills EU RoHS substance requirements	Yes
Exemption	6(c), 7(c)-I

China RoHS

Environment friendly use period (EFUP)	EFUP-50
	An article-related China RoHS declaration table can be found in the download area for the respective article under "Manufacturer declaration". For all articles with EFUP-E, no China RoHS declaration table issued and required.

EU REACH SVHC

REACH candidate substance (CAS No.)	Lead(CAS: 7439-92-1)
	2-(2H-benzotriazol-2-yl)-4-(1,1,3,3-tetramethylbutyl)phenol (UV-329)(CAS: 3147-75-9)
SCIP	257db5f4-4a92-404c-98c8-d7c6247b368d