

UKH 240 BU - High-current terminal block



0711852

<https://www.phoenixcontact.com/sg/products/0711852>

Please be informed that the data shown in this PDF document is generated from our online catalog. Please find the complete data in the user documentation. Our general terms of use for downloads are valid.



High-current terminal block, nom. voltage: 1000 V, nominal current: 415 A, number of connections: 2, number of positions: 1, connection method: Screw connection, Rated cross section: 240 mm², cross section: 70 mm² - 240 mm², mounting type: NS 35/15, NS 32, color: blue

Your advantages

- Large-surface marking

Commercial data

Item number	0711852
Packing unit	3 pc
Minimum order quantity	3 pc
Note	Made to order (non-returnable)
Sales key	0100*
Product key	BE1311
Catalog page	Page 199 (C-1-2019)
GTIN	4017918885120
Weight per piece (including packing)	495.3 g
Weight per piece (excluding packing)	471 g
Customs tariff number	85369010
Country of origin	IN

Technical data

Product properties

Product type	High current terminal block
Number of positions	1
Number of connections	2
Number of rows	1
Potentials	1

Insulation characteristics

Overvoltage category	III
Degree of pollution	3

Electrical properties

Rated surge voltage	8 kV
Maximum power dissipation for nominal condition	13.78 W

Connection data

Number of connections per level	2
Nominal cross section	240 mm ²

Level 1 above 1 below 1

Screw thread	M10
Note	Screws with hexagonal socket
Tightening torque	25 ... 30 Nm
Stripping length	40 mm
Internal cylindrical gage	B15
Connection in acc. with standard	IEC 60947-7-1
Conductor cross section rigid	70 mm ² ... 240 mm ²
Cross section AWG	3/0 ... 350 kcmil (converted acc. to IEC)
Conductor cross section flexible	70 mm ² ... 240 mm ²
Conductor cross section, flexible [AWG]	3/0 ... 350 kcmil (converted acc. to IEC)
Conductor cross-section flexible (ferrule without plastic sleeve)	70 mm ² ... 185 mm ²
Flexible conductor cross section (ferrule with plastic sleeve)	70 mm ² ... 185 mm ²
Cross-section with insertion bridge, rigid	240 mm ²
Cross-section with insertion bridge, flexible	185 mm ²
2 conductors with same cross section, solid	35 mm ² ... 95 mm ²
2 conductors with same cross section, flexible	50 mm ² ... 95 mm ²
2 conductors with same cross section, flexible, with ferrule without plastic sleeve	35 mm ² ... 50 mm ²
Nominal current	415 A
Maximum load current	415 A (with 240 mm ² conductor cross section)
Nominal voltage	1000 V
Note	Note: Product releases, connection cross sections and notes on connecting aluminum cables can be found in the download area.

UKH 240 BU - High-current terminal block



0711852

<https://www.phoenixcontact.com/sg/products/0711852>

Nominal cross section	240 mm ²
-----------------------	---------------------

Ex data

Rated data (ATEX/IECEX)

Identification	⊕ II 2 GD Ex eb IIC Gb
Operating temperature range	-60 °C ... 110 °C
Ex-certified accessories	1201947 VDE-ISS 8
	1201659 E/AL-NS 32
	1201662 E/AL-NS 35
List of bridges	Insertion bridge / EB 2-36/UKH / 0201401
	Insertion bridge / EB 3-36/UKH / 0201414
Bridge data	270 A (240 mm ²)
Ex temperature increase	40 K (389 A/240 mm ²)
Rated voltage	1100 V
at bridging with insertion bridge	690 V
Rated insulation voltage	1000 V
output	(Permanent)

Ex level General

Rated current	350 A
Maximum load current	350 A
Contact resistance	0.03 mΩ

Ex connection data General

Stripping length	40 mm
Torque range	25 Nm ... 30 Nm
Nominal cross section	240 mm ²
Rated cross section AWG	500 kcmil
Connection capacity rigid	70 mm ² ... 240 mm ²
Connection capacity AWG	2/0 ... 500 kcmil
Connection capacity flexible	70 mm ² ... 240 mm ²
Connection capacity AWG	2/0 ... 500 kcmil
2 conductors with same cross section, solid	35 mm ² ... 95 mm ²
2 conductors with the same cross-section AWG rigid	2 ... 3/0
2 conductors with same cross section, stranded	50 mm ² ... 95 mm ²
2 conductors with the same cross-section AWG flexible	1/0 ... 3/0

Dimensions

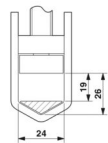
Dimensional drawing	
Width	36 mm

UKH 240 BU - High-current terminal block



0711852

<https://www.phoenixcontact.com/sg/products/0711852>

Height	100 mm
Depth	123.6 mm
Depth on NS 32	129 mm
Depth on NS 35/15	131.5 mm

Material specifications

Color	blue (RAL 5015)
Flammability rating according to UL 94	V0
Insulating material group	I
Insulating material	PA
Static insulating material application in cold	-60 °C
Relative insulation material temperature index (Elec., UL 746 B)	130 °C
Fire protection for rail vehicles (DIN EN 45545-2) R22	HL 1 - HL 3
Fire protection for rail vehicles (DIN EN 45545-2) R23	HL 1 - HL 3
Fire protection for rail vehicles (DIN EN 45545-2) R24	HL 1 - HL 3
Fire protection for rail vehicles (DIN EN 45545-2) R26	HL 1 - HL 3
Surface flammability NFPA 130 (ASTM E 162)	passed
Specific optical density of smoke NFPA 130 (ASTM E 662)	passed
Smoke gas toxicity NFPA 130 (SMP 800C)	passed

Electrical tests

Surge voltage test

Result	Test passed
Short-time withstand current 240 mm ²	28.8 kA
Result	Test passed

Power-frequency withstand voltage

Test voltage setpoint	2.2 kV
Result	Test passed

Mechanical properties

Mechanical data

Open side panel	No
-----------------	----

Mechanical tests

Mechanical strength

Result	Test passed
--------	-------------

Attachment on the carrier

DIN rail/fixing support	NS 32/NS 35
Result	Test passed

Test for conductor damage and slackening

Rotation speed	10 (+/- 2) rpm
----------------	----------------

UKH 240 BU - High-current terminal block



0711852

<https://www.phoenixcontact.com/sg/products/0711852>

Revolutions	135
Conductor cross section/weight	70 mm ² /10.4 kg 240 mm ² /20.0 kg
Result	Test passed

Environmental and real-life conditions

Needle-flame test

Time of exposure	30 s
Result	Test passed

Oscillation/broadband noise

Specification	DIN EN 50155 (VDE 0115-200):2022-06
Spectrum	Long life test category 2, bogie-mounted
Frequency	$f_1 = 5 \text{ Hz}$ to $f_2 = 250 \text{ Hz}$
ASD level	6.12 (m/s ²) ² /Hz
Acceleration	3.12g
Test duration per axis	5 h
Test directions	X-, Y- and Z-axis
Result	Test passed

Shocks

Specification	DIN EN 50155 (VDE 0115-200):2022-06
Pulse shape	Half-sine
Acceleration	5g
Shock duration	30 ms
Number of shocks per direction	3
Test directions	X-, Y- and Z-axis (pos. and neg.)
Result	Test passed

Ambient conditions

Ambient temperature (operation)	-60 °C ... 110 °C (Operating temperature range incl. self-heating; for max. short-term operating temperature, see RTI Elec.)
Ambient temperature (storage/transport)	-25 °C ... 60 °C (for a short time, not exceeding 24 h, -60 °C to +70 °C)
Ambient temperature (assembly)	-5 °C ... 70 °C
Ambient temperature (actuation)	-5 °C ... 70 °C
Permissible humidity (operation)	20 % ... 90 %
Permissible humidity (storage/transport)	30 % ... 70 %

Standards and regulations

Connection in acc. with standard	IEC 60947-7-1
----------------------------------	---------------

Mounting

Mounting type	NS 35/15 NS 32
---------------	-------------------

UKH 240 BU - High-current terminal block

0711852

<https://www.phoenixcontact.com/sg/products/0711852>

Drawings

Dimensional drawing

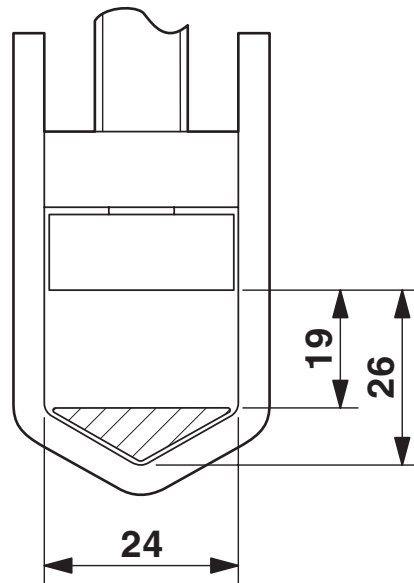

Schematic diagram

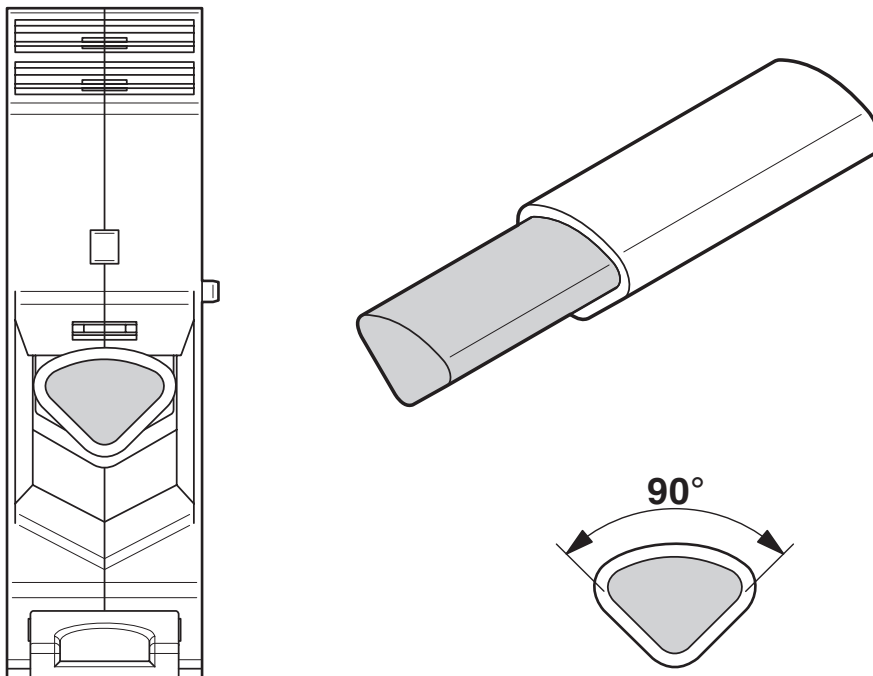

Connecting aluminum cables. Further notes can be found in the download area

UKH 240 BU - High-current terminal block

0711852

<https://www.phoenixcontact.com/sg/products/0711852>



Circuit diagram



UKH 240 BU - High-current terminal block



0711852

<https://www.phoenixcontact.com/sg/products/0711852>

Approvals

To download certificates, visit the product detail page: <https://www.phoenixcontact.com/sg/products/0711852>

DNV

Approval ID: TAE00001CT



CSA

Approval ID: 13631

	Nominal voltage U_N	Nominal current I_N	Cross section AWG	Cross section mm^2
Use group B	600 V	400 A	1/0 - 500	-
Use group C	600 V	400 A	1/0 - 500	-



cULus Recognized

Approval ID: E60425

	Nominal voltage U_N	Nominal current I_N	Cross section AWG	Cross section mm^2
Use group B	600 V	380 A	2/0 - 500	-
Multi-conductor connection	600 V	380 A	2 - 3/0	-
Use group C	600 V	380 A	2/0 - 500	-
Multi-conductor connection	600 V	380 A	2 - 3/0	-



LR

Approval ID: LR2041789TA-02



ATEX

Approval ID: KEMA99ATEX8332U

	Nominal voltage U_N	Nominal current I_N	Cross section AWG	Cross section mm^2
Type examination certificate	1100 V	350 A	-	70 - 240



IECEx

Approval ID: IECEx KEM 06.0030U

	Nominal voltage U_N	Nominal current I_N	Cross section AWG	Cross section mm^2
	1100 V	350 A	-	70 - 240

UKH 240 BU - High-current terminal block



0711852

<https://www.phoenixcontact.com/sg/products/0711852>



CCC

Approval ID: 2020322313000623



UKCA-EX

Approval ID: DEKRA 21UKEX0309U

UL Comp Hazloc CA US

Approval ID: UL US CA L 192998

	Nominal voltage U_N	Nominal current I_N	Cross section AWG	Cross section mm^2
	600 V	380 A	2/0 - 500	-

cULus Recognized

UKH 240 BU - High-current terminal block



0711852

<https://www.phoenixcontact.com/sg/products/0711852>

Classifications

ECLASS

ECLASS-11.0	27141120
ECLASS-13.0	27250101

ETIM

ETIM 9.0	EC000897
----------	----------

UNSPSC

UNSPSC 21.0	39121400
-------------	----------

UKH 240 BU - High-current terminal block



0711852

<https://www.phoenixcontact.com/sg/products/0711852>

Environmental product compliance

EU RoHS

Fulfills EU RoHS substance requirements	Yes, No exemptions
---	--------------------

China RoHS

Environment friendly use period (EFUP)	EFUP-E
	No hazardous substances above the limits

EU REACH SVHC

REACH candidate substance (CAS No.)	No substance above 0.1 wt%
-------------------------------------	----------------------------

Phoenix Contact 2025 © - all rights reserved
<https://www.phoenixcontact.com>

PHOENIX CONTACT SEA Pte. Ltd.
105 Eunos Avenue 3, #04-00
Singapore 409836
+65 6228 4900
marketing@phoenixcontact.com.sg