

AKG 16 BU - Connection terminal block



0423014

<https://www.phoenixcontact.com/sg/products/0423014>

Please be informed that the data shown in this PDF document is generated from our online catalog. Please find the complete data in the user documentation. Our general terms of use for downloads are valid.

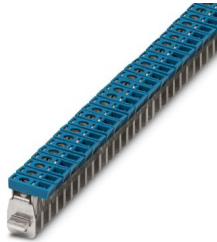

Connection terminal block, nominal current: 76 A, connection method: Screw connection, Rated cross section: 16 mm², cross section: 1.5 mm² - 16 mm², mounting: Neutral busbar, color: blue

Commercial data

Item number	0423014
Packing unit	50 pc
Minimum order quantity	50 pc
Sales key	0151*
Product key	BE7331
Catalog page	Page 555 (C-3-2019)
GTIN	4017918001995
Weight per piece (including packing)	10.574 g
Weight per piece (excluding packing)	10.426 g
Customs tariff number	85369010
Country of origin	IN

AKG 16 BU - Connection terminal block



0423014

<https://www.phoenixcontact.com/sg/products/0423014>

Technical data

Product properties

Product type	Installation terminal block
Number of positions	1.00
Number of connections	1
Number of rows	1

Electrical properties

Maximum load current	76 A (with 16 mm ² conductor cross section)
Maximum power dissipation for nominal condition	2.43 W
Nominal current I _N	76 A
Current carrying capacity of the neutral busbar	140 A

Connection data

Nominal cross section	16 mm ²
Maximum load current	76 A (with 16 mm ² conductor cross section)

Level 1 above 1 below 1

Screw thread	M5
Tightening torque	2.5 ... 3 Nm
Stripping length	16 mm
Internal cylindrical gage	B6
Conductor cross section rigid	1.5 mm ² ... 16 mm ²
Cross section AWG	14 ... 6 (converted acc. to IEC)
Conductor cross section flexible	1.5 mm ² ... 16 mm ²
Conductor cross section, flexible [AWG]	14 ... 6 (converted acc. to IEC)
Conductor cross-section flexible (ferrule without plastic sleeve)	1.5 mm ² ... 16 mm ²
Flexible conductor cross section (ferrule with plastic sleeve)	1.5 mm ² ... 16 mm ²
2 conductors with same cross section, solid	1.5 mm ² ... 6 mm ²
2 conductors with same cross section, flexible	1.5 mm ² ... 6 mm ²
2 conductors with same cross section, flexible, with ferrule without plastic sleeve	1.5 mm ² ... 6 mm ²
2 conductors with the same cross section, flexible, with TWIN ferrule with plastic sleeve	1.5 mm ² ... 10 mm ²
Nominal current	76 A
Maximum load current	76 A (with 16 mm ² conductor cross section)
Nominal cross section	16 mm ²

Dimensions

AKG 16 BU - Connection terminal block



0423014

<https://www.phoenixcontact.com/sg/products/0423014>

Dimensional drawing	
Width	9.8 mm
Height	23.4 mm
Depth	32 mm
Length	23.5 mm

Material specifications

Color	blue (RAL 5015)
Flammability rating according to UL 94	V2
Insulating material	PA
Temperature index of insulation material (DIN EN 60216-1 (VDE 0304-21))	125 °C
Relative insulation material temperature index (Elec., UL 746 B)	125 °C

Electrical tests

Temperature-rise test

Requirement temperature-rise test	Increase in temperature ≤ 45 K
Result	Test passed
Short-time withstand current 16 mm ²	1.92 kA
Result	Test passed

Mechanical tests

Mechanical strength

Result	Test passed
--------	-------------

Test for conductor damage and slackening

Rotation speed	10 rpm
Revolutions	135
Conductor cross section/weight	1.5 mm ² / 0.4 kg
	16 mm ² / 2.9 kg
Result	Test passed

Environmental and real-life conditions

Ambient conditions

Ambient temperature (operation)	-60 °C ... 110 °C (Operating temperature range incl. self-heating; for max. short-term operating temperature, see RTI Elec.)
---------------------------------	--

AKG 16 BU - Connection terminal block



0423014

<https://www.phoenixcontact.com/sg/products/0423014>

Ambient temperature (storage/transport)	-25 °C ... 60 °C (for a short time, not exceeding 24 h, -60 °C to +70 °C)
Ambient temperature (assembly)	-5 °C ... 70 °C
Ambient temperature (actuation)	-5 °C ... 70 °C
Permissible humidity (operation)	20 % ... 90 %
Permissible humidity (storage/transport)	30 % ... 70 %

Mounting

Mounting type	Neutral busbar
---------------	----------------

AKG 16 BU - Connection terminal block

0423014

<https://www.phoenixcontact.com/sg/products/0423014>

Drawings

Dimensional drawing

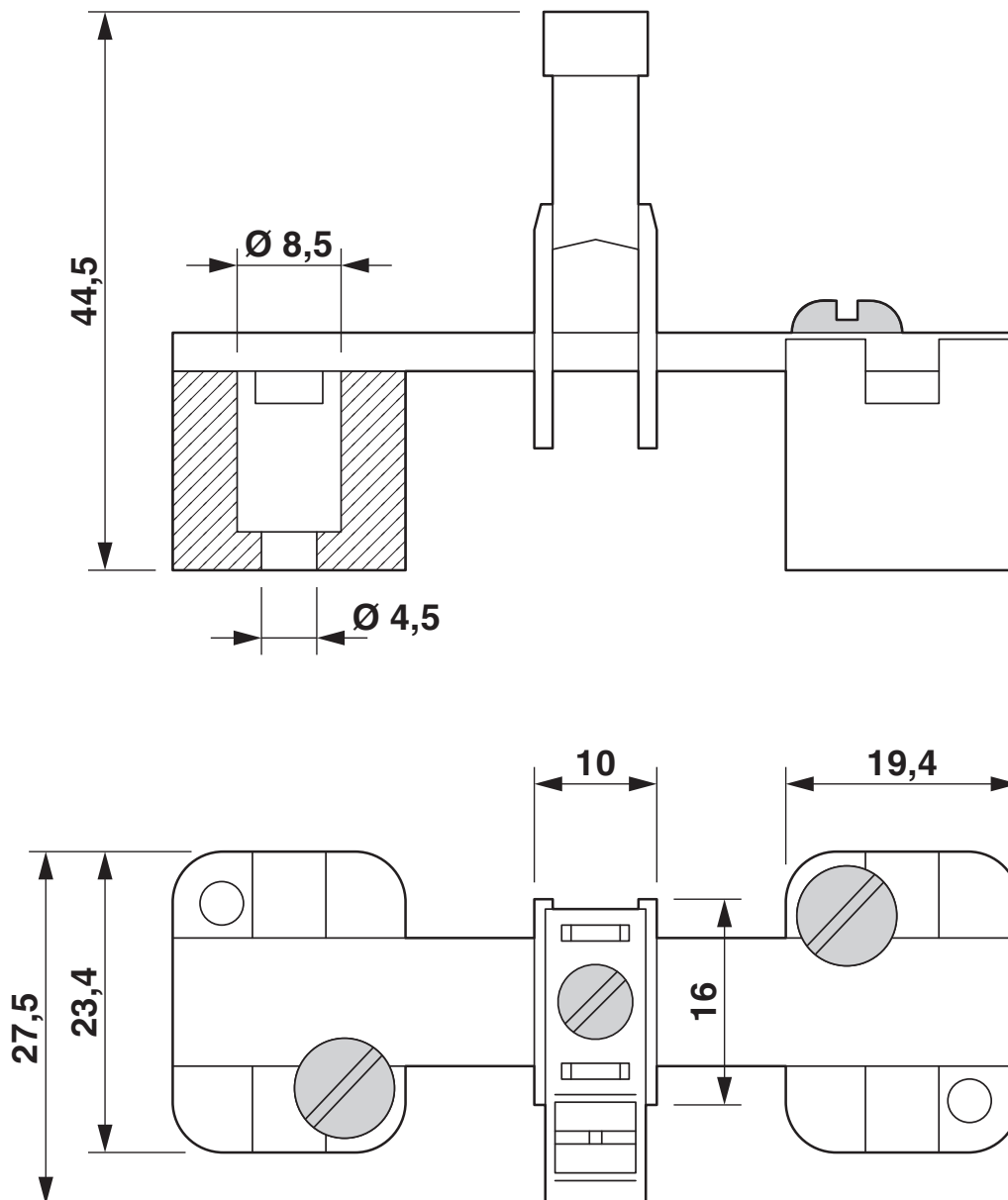

AKG 16 BU - Connection terminal block



0423014

<https://www.phoenixcontact.com/sg/products/0423014>

Dimensional drawing

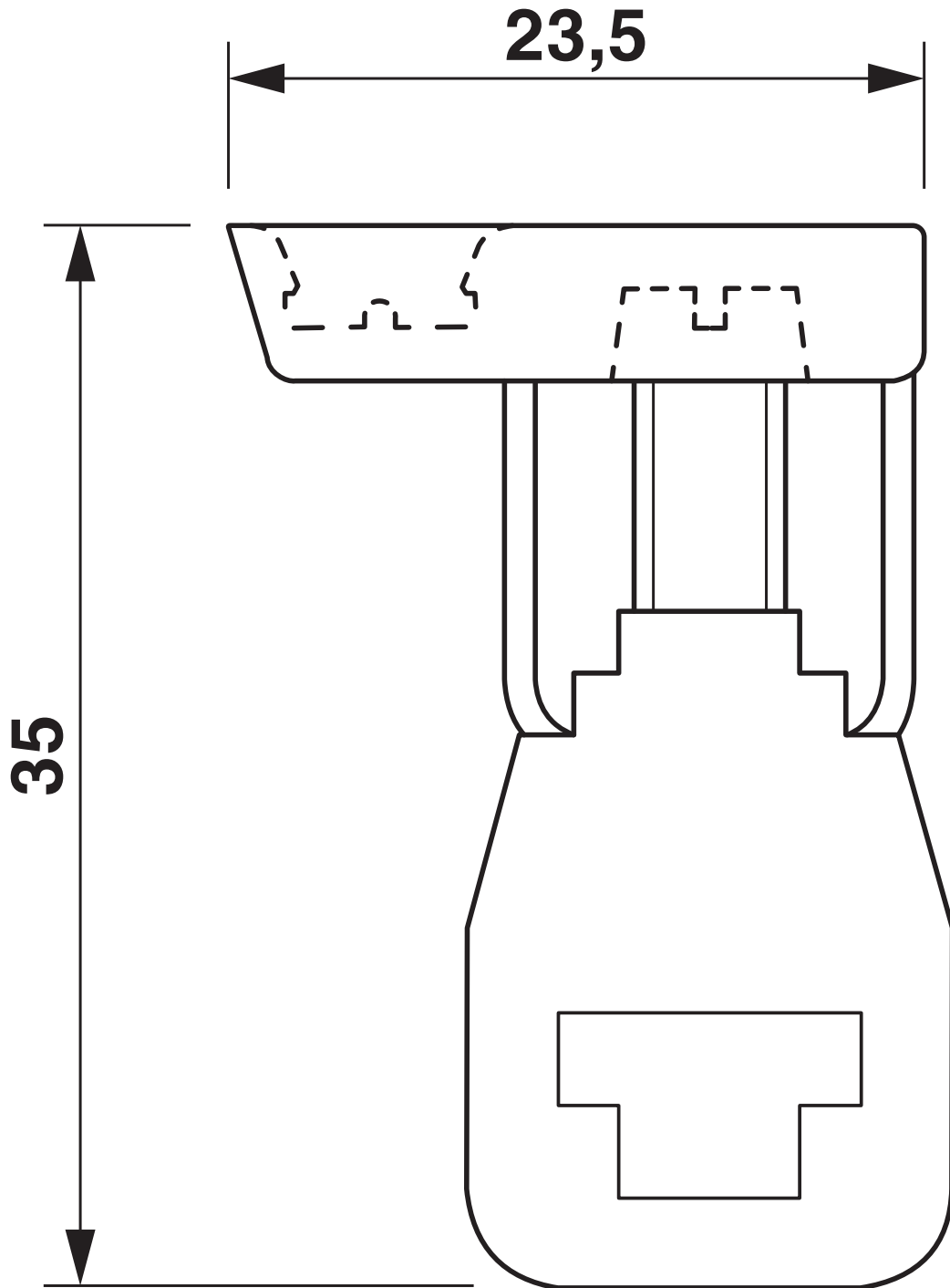

AKG 16 BU - Connection terminal block



0423014

<https://www.phoenixcontact.com/sg/products/0423014>

Circuit diagram



AKG 16 BU - Connection terminal block





0423014

<https://www.phoenixcontact.com/sg/products/0423014>

Approvals

To download certificates, visit the product detail page: <https://www.phoenixcontact.com/sg/products/0423014>

 CSA Approval ID: 13631				
	Nominal voltage U_N	Nominal current I_N	Cross section AWG	Cross section mm^2
	-	65 A	18 - 6	-

 UL Recognized Approval ID: E60425				
	Nominal voltage U_N	Nominal current I_N	Cross section AWG	Cross section mm^2
Use group B	-	65 A	18 - 6	-
Use group C	-	65 A	18 - 6	-
Use group F	-	65 A	18 - 6	-

 EAC Approval ID: EACKZ 08593				
--	--	--	--	--

AKG 16 BU - Connection terminal block



0423014

<https://www.phoenixcontact.com/sg/products/0423014>

Classifications

ECLASS

ECLASS-11.0	27141146
ECLASS-12.0	27141146
ECLASS-13.0	27250116

ETIM

ETIM 9.0	EC000001
----------	----------

UNSPSC

UNSPSC 21.0	31162900
-------------	----------

AKG 16 BU - Connection terminal block



0423014

<https://www.phoenixcontact.com/sg/products/0423014>

Environmental product compliance

EU RoHS

Fulfills EU RoHS substance requirements	Yes, No exemptions
---	--------------------

China RoHS

Environment friendly use period (EFUP)	EFUP-E
	No hazardous substances above the limits

EU REACH SVHC

REACH candidate substance (CAS No.)	No substance above 0.1 wt%
-------------------------------------	----------------------------

Phoenix Contact 2025 © - all rights reserved
<https://www.phoenixcontact.com>

PHOENIX CONTACT SEA Pte. Ltd.
105 Eunos Avenue 3, #04-00
Singapore 409836
+65 6228 4900
marketing@phoenixcontact.com.sg