



Compact, Locking Safety Door Switch with Dual Key Entry

- Slow-action contacts feature positive opening mechanism 
- Select mechanical lock/solenoid release or solenoid lock/mechanical release models
- Operation indicator shows operation status at a glance
- Double-insulation structure requires no grounding terminals (with  mark)
- Three types of key operation include horizontal mounting, vertical mounting, angle-adjustable vertical mounting
- Approved Standards







Agency	Standard	File No.
TÜV Rheinland	EN60947-5-1	J9650735
BIA	EN60947-5-1, GS-ET-19	9610568
UL (See Note.)	UL508, CSA C22.2 No.14	E76675
SUVA	SUVA (pending)	---



Note: Approval for CSA C22.2 No. 14 is authorized by  mark.

Ordering Information

■ SWITCHES

Conduit type	Lock type	Voltage for Solenoid	With LED indicator 1NC  /1NO+1NC (Slow action)	With neon lamp indicator 1NC  /1NO+1NC (Slow action)	With LED indicator 2NC  +1NC (Slow action)	With neon lamp indicator 2NC  +1NC (Slow action)
PG13.5 (2 conduits)	Mechanical lock	24 VDC	D4DL-1CFA-B	---	D4DL-1DFA-B	---
		110 VAC	D4DL-1CFB-B	---	D4DL-1DFB-B	---
		230 VAC	---	D4DL-1CFC-E	---	D4DL-1DFC-E
	Solenoid lock	24 VDC	D4DL-1CFG-B	---	D4DL-1DFG-B	---
		110 VAC	D4DL-1CFH-B	---	D4DL-1DFH-B	---
		230 VAC	---	D4DL-1CFJ-E	---	D4DL-1DFJ-E



Note: "" marking indicates the contacts which have positive opening mechanism approved by TÜV Rheinland.

■ OPERATION KEYS

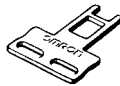
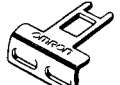
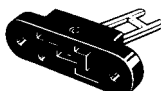
Note: D4DL uses the same keys as D4DS

Type	Part number
Horizontal mounting 	D4DS-K1
Vertical mounting 	D4DS-K2
Angle-adjustable vertical mounting 	D4DS-K3

■ ACCESSORIES

Description	Part number
Cable gland for D4DL 	PG13.5 FITTING
Conduit change adapter PG13.5 to 1/2-14NPT 	PG13.5 to NPT ADAPTOR

■ MODEL NUMBER LEGEND

Switches

D4DL------

1 2 3 4 5

- Conduit Size (2-conduit)**
1: Pg13.5
- Built-in Switch (with Safety Switch and Lock Monitor Switch Contacts)**
C: 1NC/1NO slow-action contacts plus 1NC slow-action contact
D: 2NC slow-action contacts plus 1NC slow-action contact
- Head Mounting Direction**
F: Front
- Door Lock and Release**
These apply power to solenoid to *unlatch*:
A: Mechanical lock / 24-VDC solenoid release
B: Mechanical lock / 110-VAC solenoid release
C: Mechanical lock / 230-VAC solenoid release
These apply power to solenoid to *latch*:
G: 24-VDC solenoid lock / mechanical release
H: 110-VAC solenoid lock / mechanical release
J: 230-VAC solenoid lock / mechanical release

- Indicator**
B: 10 to 115 VAC/VDC (with orange LED indicator)
E: 100 to 250 VAC (with orange neon lamp indicator)

Operation Keys

Note: D4DL uses the same keys as D4DS

D4DS-K

1

- Key Type**
1: Horizontal mounting
2: Vertical mounting
3: Horizontal-adjustable vertical mounting
5: Vertical/Horizontal-adjustable vertical mounting

Specifications

■ RATINGS

These Figures are Steady-State Current Values

Rated voltage	Non-inductive load (A)				Inductive load (A) (See Note 1.)			
	Resistive load		Lamp load (See Note 2.)		Inductive load		Motor load (See Note 3.)	
	NC	NO	NC	NO	NC	NO	NC	NO
125 VAC	10		3	1.5	10		5	2.5
250 VAC	10		2	1	10		3	1.5
8 VAC	10		6	3	10		6	
14 VAC	10		6	3	10		6	
30 VAC	6		4	3	6		4	
125 VAC	0.8		0.2	0.2	0.8		0.2	
250 VAC	0.4		0.1	0.1	0.4		0.1	
Inrush current	Normally closed: 30 A max. Normally open: 30 A max.							

Note: 1. The inductive load has an AC power factor of 0.4 min. or a DC time constant of 7 ms max.

2. The lamp load has an inrush current 10 times the steady-state current.

3. The motor load has an inrush current 6 times the steady-state current.

Approved Standard Ratings

TÜV (EN60947-5-1)

Item	LED type	Neon lamp type
Utilization category	AC-15	AC-15
Rated operating current (I_{θ})	6 A	3 A
Rated operating voltage (U_{θ})	115 V	250 V

UL/CSA (UL508, CSA C22.2 No. 14) A300

Rated voltage	Carry current	Current (A)		Voltage	
		Make	Break	Make	Break
120 VAC	10A	60	6	7,200	720
240 VAC		30	3		

■ CHARACTERISTICS

Enclosure rating (See Note 1.)	UL	3, 4, and 13
	NEMA	3, 4 and 13
	IEC529	IP65 (EN60947-5-1)
Life expectancy (See Note 2.)	Mechanical	1,000,000 times min.
	Electrical	500,000 times min.
Operating speed		0.05 to 0.5 m/s
Operating frequency		30 operations/minute max.
Rated frequency		50/60 Hz
Positive opening force		58.84 N (6 kgf) min. (EN60947-5-1)
Positive opening travel		10 mm min. (EN60947-5-1)
Holding force		500 N (51 kgf) min. (GS-ET-19)
Insulation resistance		100 M Ω min. (at 500 VDC)
Rated insulation voltage (U _i)		300 V (EN60947-5-1)
Conventional enclosed thermal current (I _{the})		10 A (EN60947-5-1)
Rated impulse voltage (U _{imp})		Between terminals of same or different polarity, each terminal and ground, and each terminal and non-current-carrying metal part: 4 kV Between the solenoid and non-current-carrying metal part: 0.8 kV for 24 VDC solenoid, 2.5 kV for 110 VAC solenoid, and 4 kV for 230 VAC solenoid (EN60947-5-1)
Conditional short-circuit current		100 A (EN60947-5-1)
Pollution degree (operating environment)		3 (EN60947-5-1)
Protection against electric shock		Class II (double insulation)
Switching overvoltage		1,500 V max. (EN60947-5-1)
Contact resistance		25 m Ω max. (initial value)
Vibration resistance		Malfunction: 10 to 55 Hz, 0.75-mm single amplitude
Shock resistance		Mechanical: 1,000 m/s ² (100G) min. (IEC68-2-27) Malfunction: 300 m/s ² (30G) min. (IEC68-2-27)
Ambient temperature	Operating	-10°C to 55°C (14°F to 131°F) with no icing
Ambient humidity	Operating	95% max.
Weight		Approx. 340 g
Material	Body and actuator flange	Glass-fiber reinforced thermoplast, self-extinguishing
	Actuator	Stainless steel

Note: 1. Although the switch box is protected from dust or water penetration, to avoid switch malfunctioning or damage – do not use the D4DL in places where foreign material may penetrate through the key hole on the head.

2. The above mechanical or electrical life is ensured at an ambient temperature of 5°C to 35°C (41°F to 95°F) and an ambient humidity of 40% to 70%.

■ SOLENOID COIL CHARACTERISTICS

Model	24 VDC	110 VAC	230 VAC
Rated operating voltage	24 VDC +10%/–15% (100% ED)	110 VAC \pm 10% (100% ED)	230 VAC \pm 10% (100% ED)
Current consumption	Approx. 200 mA	Approx. 50 mA	Approx. 30 mA
Insulation	Class F (130°C max.)	Class F (130°C max.)	Class F (130°C max.)

■ INDICATOR CHARACTERISTICS

Model	LED	Neon lamp
Rated voltage	10 to 115 VAC/VDC	100 to 250 VAC
Current leakage	Approx. 1 mA	Approx. 1.9 mA
Color	Orange	Orange

■ D4DL SAFETY DOOR SWITCH

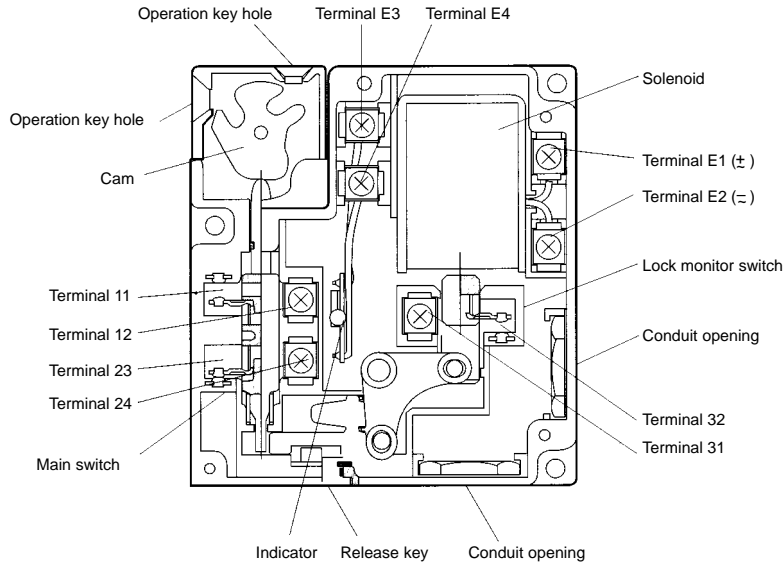

Operation

■ CONTACTS

Model	Contact	Contact form	Diagram	Remarks
D4DL-□C□□□□	1NC/1NO + 1NC			Only terminals 11, 12, 31, and 32 have a positive opening mechanism.
D4DL-□D□□□□	2NC + 1NC			Terminals 11, 12, 21, 22, 31, and 32 have a positive opening mechanism.

■ INDICATOR

LED Type

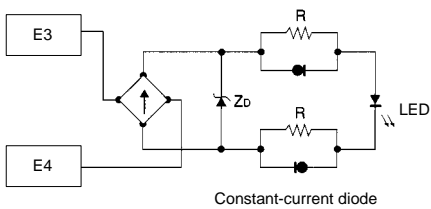

Neon Lamp Type

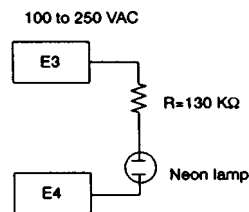

■ CIRCUIT CONNECTION EXAMPLE

Circuit is to be connected by user.

- Connect terminals 12 to 31.
- Do not connect the indicator in parallel to the contacts.
- The 24-VDC solenoid has polarity. Be sure not to make wiring mistakes.
- In the following connection example, the indicator will be lit when the door is open.

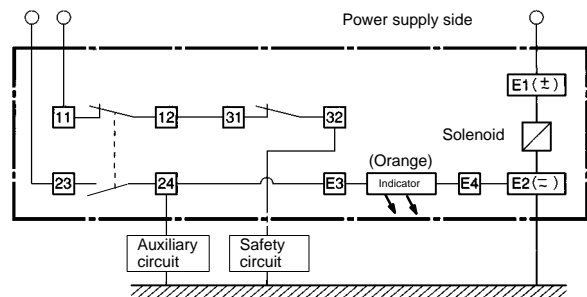

■ CONNECTION EXAMPLE WITH OMRON G9S SAFETY RELAY UNIT

G9S-301 (24 VDC)+D4DL-□CFG-B (Solenoid lock type)+D4D-□520 N

Circuit Diagram

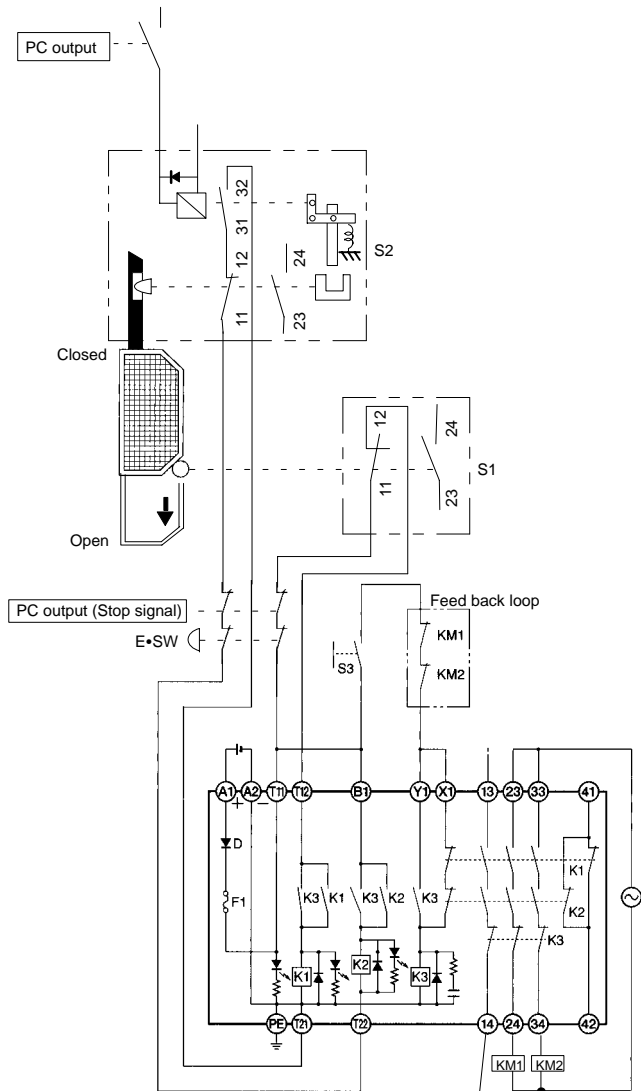

Product Configuration

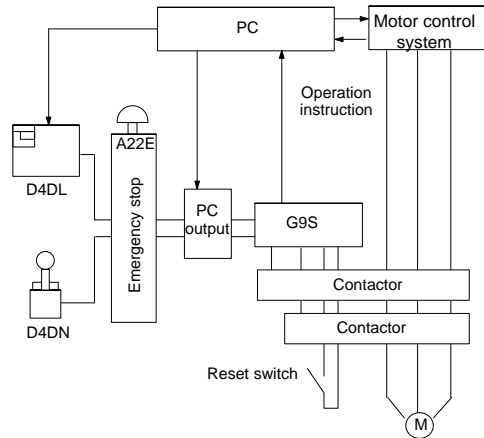

- S1: Safety Switch (D4D-□520N)
- S2: Safety Door Switch with solenoid lock (D4DL-□CFG-B)
- S3: Reset switch
- E•SW: Emergency-stop switch (A22E)
- KM1, KM2: Magnet Contactor (LC1-D)
- M: 3-phase motor

G9S-321-T□ (24 VDC)+D4DL-□CFA-B (Mechanical lock type)+D4D-□520N

Circuit Diagram

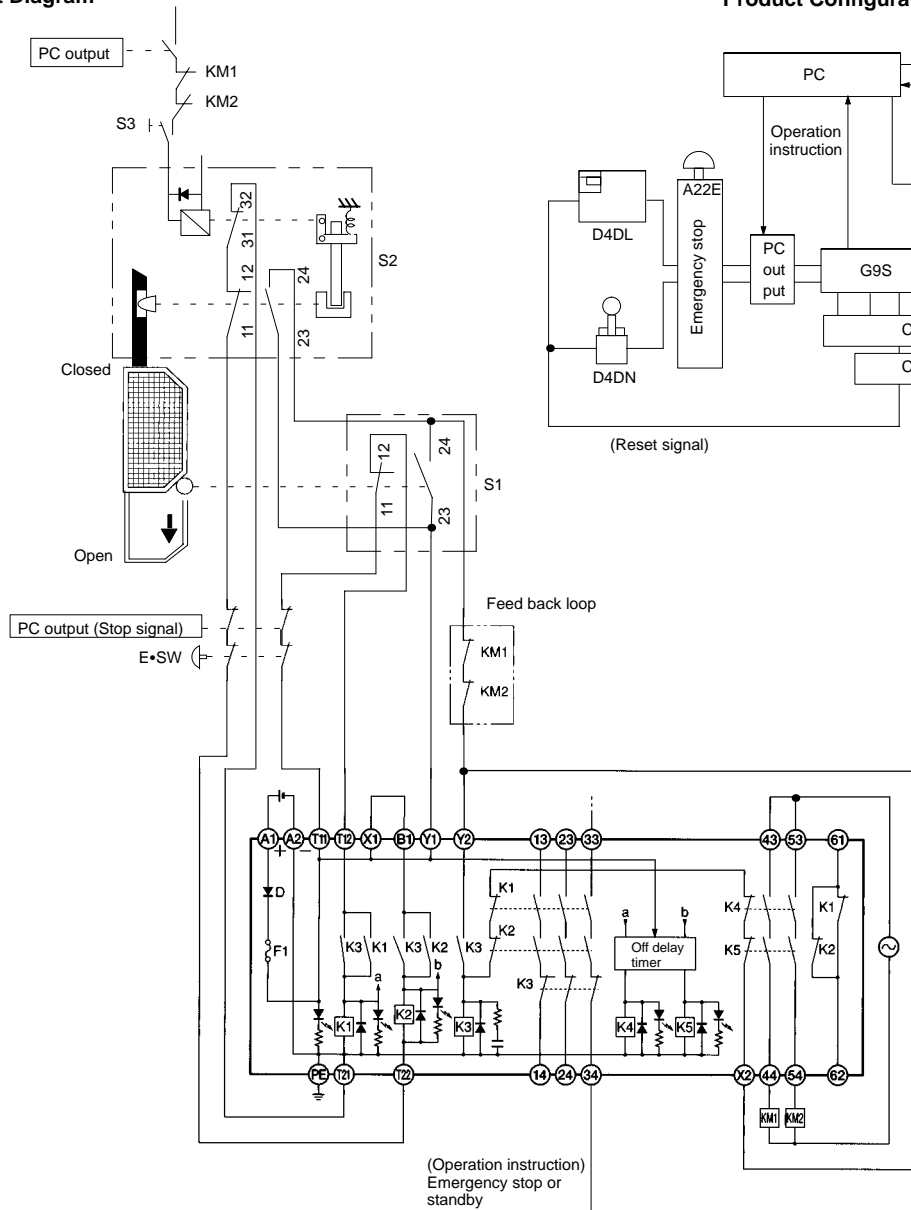

Product Configuration

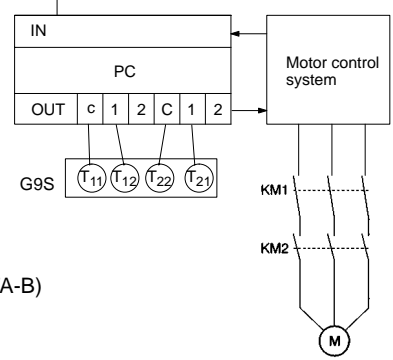
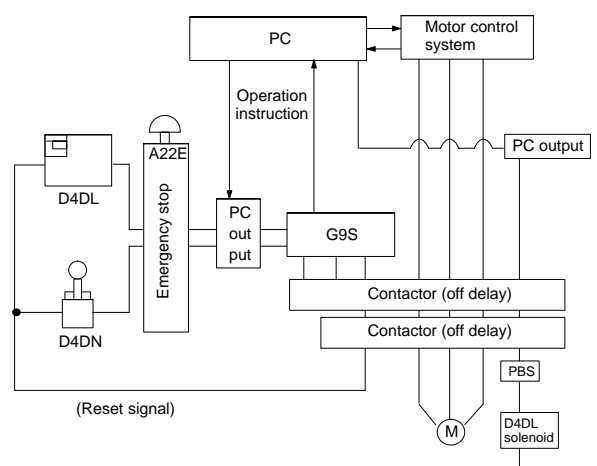

- S1: Safety Switch (D4D-□520N)
- S2: Safety Door Switch with solenoid lock (D4DL-□CFA-B)
- S3: Pushbutton switch for solenoid
- E•SW: Emergency-stop switch (A22E)
- KM1, KM2: Magnet Contactor (LC1-D)
- M: 3-phase motor

Dimensions

Unit: mm (inch)

SWITCH

D4DL-□□□□-□

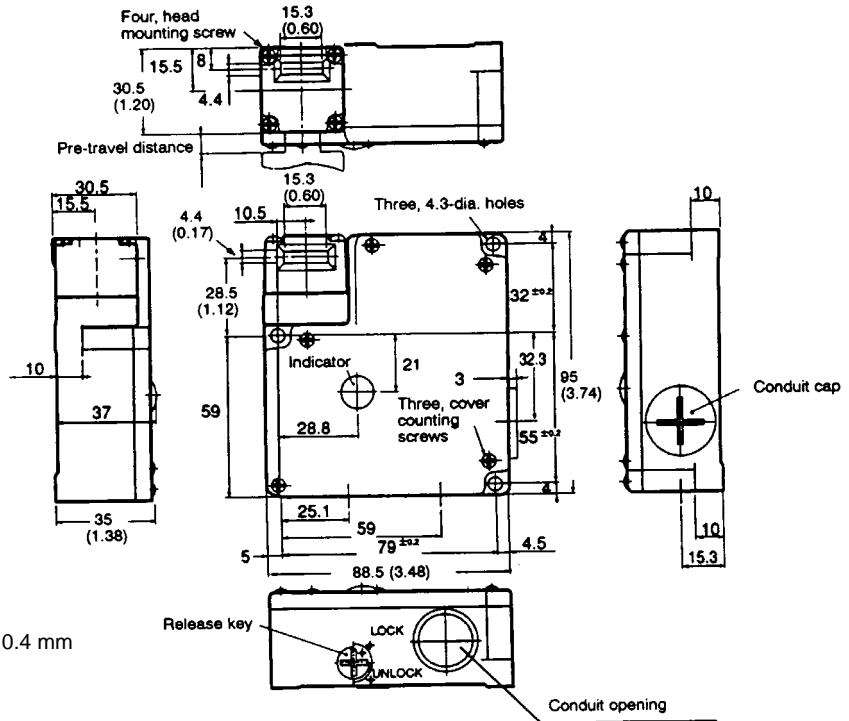
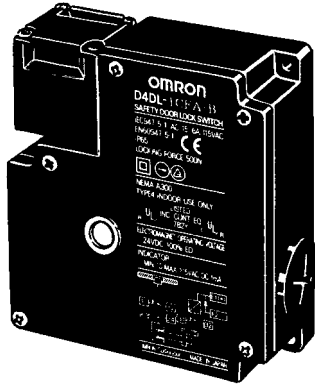

- Note: 1. Each dimension has a tolerance of ± 0.4 mm unless otherwise specified.
- 2. D4DL uses the same keys as D4DS.

OPERATION KEY

Operating characteristics	Rating
Key insertion force	14.71 N (1,500 gf) max.
Key extraction force	29.42 N (3,000 gf) max.
Pre-travel distance	9 mm max.

D4DS-K1
Horizontal Mounting

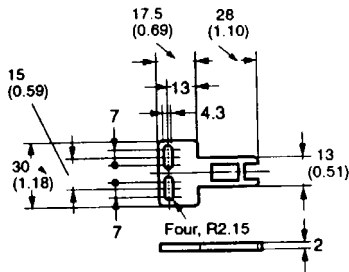
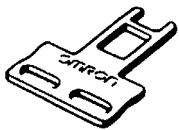

D4DS-K2
Vertical Mounting

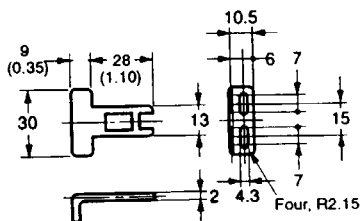
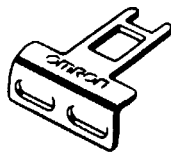

D4DS-K3
Angle-adjustable Vertical Mounting

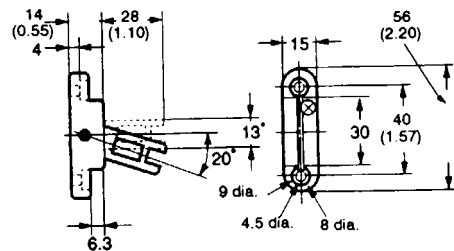
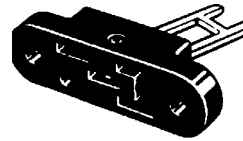

■ OPERATION KEY INSERTED

D4DL + D4DS-K1

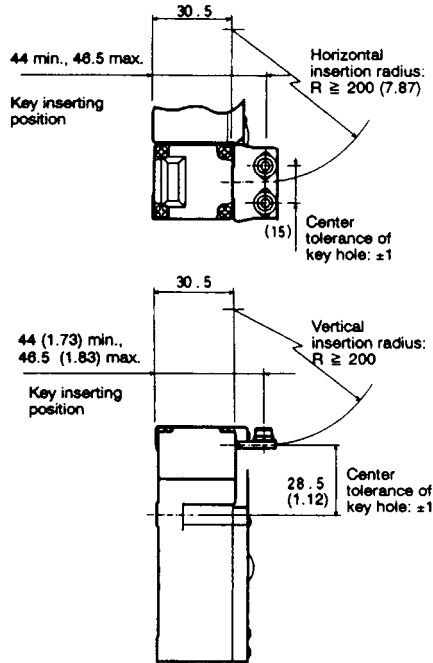

D4DL + D4DS-K2

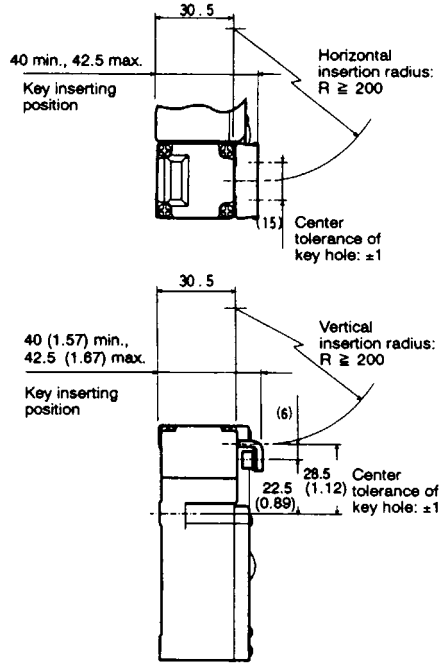
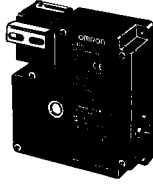

D4DL + D4DS-K3

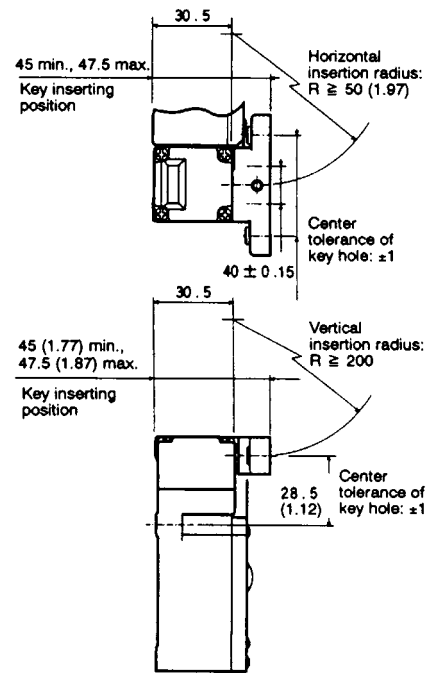
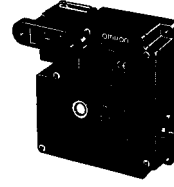

- Note: 1. Each dimension has a tolerance of ± 0.4 mm unless otherwise specified.
 2. D4DL uses the same keys as D4DS

Installation

■ MOUNTING

- When applying the D4DL to the door of a machine room, be sure to provide a stopper for the door as shown in the following illustration. Do not use the Switch as a stopper.
- Adjust the mounting position of the Operation Key so that the Operation Key will be within the 3-mm lock range of the D4DL when the door is closed (i.e., the distance (a) in the following illustration is within 3 mm).

Correct

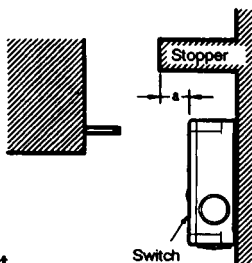

Incorrect

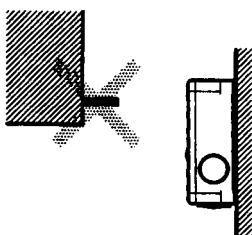

- Be sure that the Operation Key can be inserted properly with a tolerance of ± 1 mm in the upward, downward, left, or right direction, or the D4DL may be damaged. Refer to page 10 for the mounting dimensions of the Operation Key.

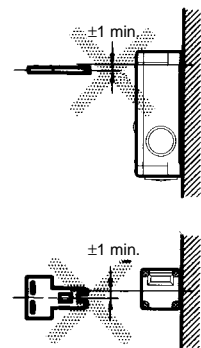

■ TIGHTENING TORQUE

- Be sure to tighten each screw of the D4DL properly. Failure to do so may cause the D4DL to malfunction.

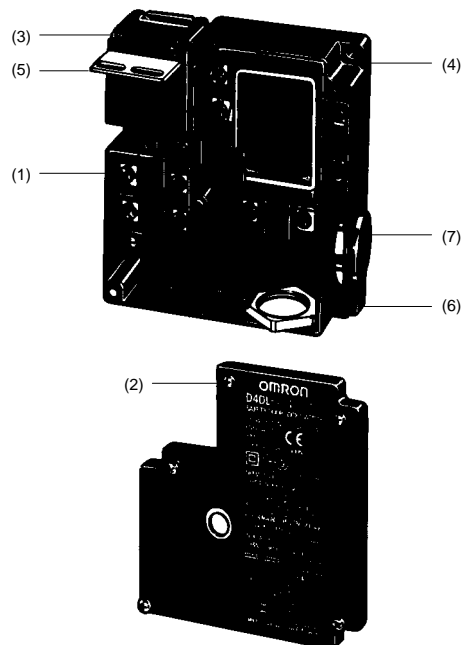

No.	Type	Proper tightening torque
(1)	Terminal screw	0.59 to 0.78 N • m (6 to 8 kgf • cm/0.43 to 0.58 ft • lbf)
(2)	Cover mounting screw	0.78 to 0.88 N • m (8 to 9 kgf • cm/0.58 to 0.65 ft • lbf)
(3)	Head mounting screw	0.78 to 0.88 N • m (8 to 9 kgf • cm/0.58 to 0.65 ft • lbf)
(4)	Body mounting screw (M4) (See Note.)	0.49 to 0.69 N • m (5 to 7 kgf • cm/0.36 to 0.51 ft • lbf)
(5)	Operation Key mounting screw	2.35 to 2.75 N • m (24 to 28 kgf • cm/1.73 to 2.03 ft • lbf)
(6)	Connector at conduit opening	1.77 to 2.16 N • m (18 to 22 kgf • cm/1.30 to 1.59 ft • lbf)
(7)	Cap screw	1.27 to 1.67 N • m (13 to 17 kgf • cm/0.94 to 1.23 ft • lbf)

Note: Tighten each screw together with a washer to the specified torque.

■ SECURE WITH M4 SCREWS AND WASHERS

Use M4 screws (one-way screws, etc.) and washers to mount the D4DL and Operation Key securely.

Be sure that the D4DL operates properly after mounting and adjusting the D4DL.

Switch Mounting Holes

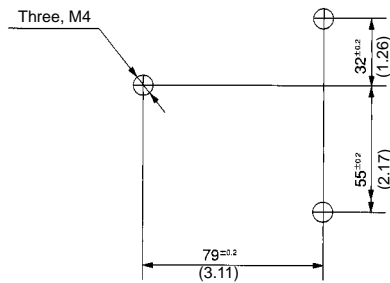

Operation Key Mounting Holes

- Horizontal/Vertical Mounting
D4DSK1/D4DS-K2

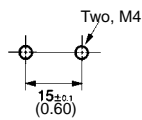

- Angle-adjustable Vertical Mounting
D4DS-K3

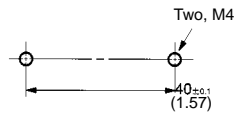

Head Direction

By removing four screws from the head, the mounting direction can be changed. The head can be mounted in four directions.

When changing the direction of the head, be sure that the Operation Key is inserted into the head and no foreign material can enter during the change.

■ WIRING

Do not connect lead wires directly to the terminals. Be sure to connect the lead wires through insulation tubes and crimp terminals. The tightening torque applied to each crimp terminal is 0.59 to 0.78 N • m (6 to 8 kgf • cm). The lead wires must be an AWB20 to AWG18 type (i.e., 0.5 to 10 mm² thick).

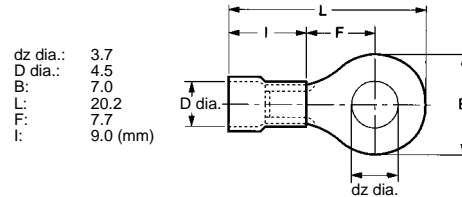

Wire the crimp terminal as shown in the following diagram so that it will not come in contact with the case or cover.

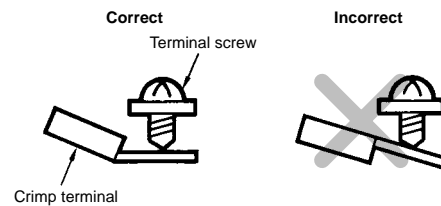

Conduit Opening

The torque required to tighten the conduit cap is 1.77 to 2.16 N • m (18 to 22 kgf • cm).

Be sure that the diameter of the cable connected to the connector is correct.

Attach and tighten a conduit cap to the unused conduit opening when wiring the D4DL. The torque to be applied to tighten the conduit cap is 1.27 to 1.67 N • m (13 to 17 kgf • cm). The conduit cap is provided with the D4DL.

Precautions



WARNING

- Do not remove the operation key from the door. Do not insert the key into the switch with the door open. Dangerously unexpected operation of the machine could result and cause serious injury.
- To avoid risk of electric shock: Do not disassemble or touch inside the D4DL when the power is ON. Do not touch the live switch terminal.
- Do not use metal connectors or conduits with this switch. Rigid connectors and conduits may damage the switch. A broken conduit hole increases the risk of an electrical shock hazard.
- Protect the D4DL with an appropriate cover and post a warning sign near the D4DL. If the D4DL or Operation Key is carelessly removed, unexpected operation of the machine can cause serious injury.

FUSE

- Put a protective fuse into solenoid circuit to prevent a possibility that overvoltage could burn the solenoid.
- To prevent the D4DL from damage due to short-circuits, connect the D4DL in series to a fuse that has a breaking current 1.5 to 2 times the rated current of the D4DL. If the D4DL is used under EN-approved rating conditions, use a 10 A fuse, type gI or gG conforming to IEC 269.

USAGE

Evaluate

- After installation, be sure to evaluate the Switch under actual working conditions.
- Use OMRON's D4BL Switch under conditions requiring a sturdy switch, higher sealability, and oil-tightness.

Operating Environment

- The D4DL is for indoor use only. Do not use the D4DL outdoors.
- Be sure that no metal dust, oil, or chemical will be sprayed onto the D4DL, or the D4DL may malfunction.
- The head uses grease internally, which may have a bad influence on semiconductor products. When using the D4DL for the door of a semiconductor product manufacturing room, mount the D4DL to the outside of the door.

Solenoid

- Do not touch the solenoid while the power is supplied. The solenoid radiates heat when power is supplied to the solenoid.

MAINTENANCE AND REPAIRS

- The user must never attempt to repair or maintain the switch. Contact the machine manufacturer for any repairs or maintenance. (Please note that this is stated in the machine manufacturer's instruction manual.)

OPERATION KEY

- Be sure to use the dedicated Operation Key only. Do not operate the D4DL with anything other than the dedicated Operation Key, or the safety of the system may not be maintained.
- Do not impose excessive force on the Operation Key inserted into the D4DL or drop the D4DL with the Operation Key inserted. Dropping the Operation Key may break or severely bend or damage the key.

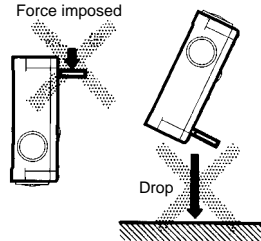

RELEASE KEY

The release key is used to unlock the D4DL in case of emergency or if the power supply to the D4DL fails.

Use an appropriate tool to set the release key to UNLOCK so the lock will be released and the door can be opened.

Mechanical Lock Type

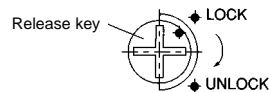

- In an application where the release key applied to the door of a machine room ensures the safety of people adjusting the equipment inside the machine room – if the release key is set to UNLOCK, the door will *not* be locked when the door is closed and *no power* will be supplied to the equipment.
- Do not use the release key to start or stop machines.
- To prevent the release key from being used carelessly by unauthorized people, set the release key of the D4DL in normal operation to UNLOCK and seal the release key with seal wax.

Solenoid Lock Type (Power to Latch)

The solenoid lock locks the door only when power is supplied to the solenoid. Because of this, the door will be unlocked if the power supply to the solenoid fails.

- Do not use D4DL models that have solenoid locks for machines that may be dangerous even after the machine loses power.
- Secure the Operation Key with a one-way screw, or an equivalent, so that the Operation Key cannot be easily removed.

DOORS

If a force exceeding holding force is imposed on the D4DL, the lock mechanism may break and the equipment in the machine room will continue to operate. (Refer to the example above.)

- The closed door must be secured with an appropriate bracket so that the Operation Key will be within the 3-mm lock range of the D4DL.
- If the Operation Key is continuously pulled in the opening direction due to a force caused by vibration, by the door itself due to its weight, or by a cushion that may be attached to the door, the D4DL may be damaged.

NOTE: DIMENSIONS SHOWN ARE IN MILLIMETERS. To convert millimeters to inches divide by 25.4.

OMRON[®]
OMRON ELECTRONICS, INC.
One East Commerce Drive
Schaumburg, IL 60173
1-800-55-OMRON

OMRON CANADA, INC.
885 Milner Avenue
Scarborough, Ontario M1B 5V8
416-286-6465